

Easy Weigh®

OWNER'S MANUAL

MODEL: PC-100 PRICE COMPUTING SCALE



VER 2.20

TABLE OF CONTENTS

SPECIFICATIONS	1
NOMENCLATURE	1
FUNCTION KEYS	2
DISPLAY	3
UNPACKING & ASSEMBLY	4
SAFETY PRECAUTIONS	5
OPERATING THE SCALE	6
PROGRAM MODE	8
CHECK STAND OPERATION	10
OPTIONS & ACCESSORIES	11
TROUBLESHOOTING & ERROR MESSAGES	11
CABLE DIAGRAMS	11
INTERFACE CROSS REFERENCE CHART	12
WARRANTEE (Supplied as separate document.)	

PREFACE

Easy Weigh[®] would like to thank you for purchasing our model PC-100 Advanced Price Computing scale. We are committed to creating high quality low maintenance products and supplying our customers with diligent customer service. This manual contains information on the proper assembly and use of the scale.

Disclaimer:

This company makes no representations or warranties, either expressed or implied, with respect to the contents hereof and specifically disclaims any warranties of merchantability or fitness for any particular purpose. Any software described in this manual is sold or licensed "as is". Should the programs prove defective following their purchase, the buyer (and not this company, its distributors, or its dealers) assumes the entire cost of all necessary servicing, repair, and any incidental or consequential damages resulting from any defect in the software. Further, this company reserves the right to revise this publication and to make changes from time to time in the contents hereof without obligation to notify any person of such revision or changes.

Brand and product names are trademarks and/or registered trademarks of their respective companies.

Specifications

Model:	PC-100	
Maximum Capacity:	30 / 60 lb Dual Range	
Minimum Graduation:	Dual Range 0 to 30 lb x 0.01 lb / 30 to 60 lb x 0.02 lb	
Maximum Tare:	Half Capacity 0 to 29.99 lb	
Internal Resolution:	60,000 Counts (minimum)	
A/D Conversion Rate:	9 Updates / second	
Direct PLU Keys:	Standard Display: Up to 6 Direct PLUs	
	Pole Display: Up to 38 Direct PLUs	
Indirect PLUs:	OR	200 Indirect PLUs (Unit Price Data ONLY)
		100 Indirect PLUs (BOTH Unit Price & Tare Data)
Vacuum Fluorescent Displays:	Weight:	5 Digits, 999.99 (60 lb max)
	Unit Price:	6 Digits, 9999.99 max
	Total Price:	6 Digits, 9999.99 max
Platter Size:	Width:	350 mm / 13.8"
	Length:	270 mm / 10.6"
Product Dimensions:	Pole Display	
	Width:	365 mm / 14.4"
	Length:	365 mm / 14.4"
	Height:	470 mm / 18.5"
		Standard Display
		Width: 365 mm / 14.4"
		Length: 365 mm / 14.4"
		Height: 160 mm / 6.3"
Power Requirements:	120 Volts AC @ 60 Hz	
Operating Temp:	-10° C ~ 40° C / 14° F ~ 104° F	
Humidity	RH 35% ~ 85%(no condensation)	
Power consumption	Approx. 6 Watt	
Fuse rating	250V / 200mA, 20mm	

Nomenclature

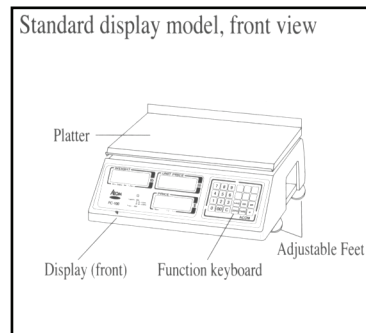
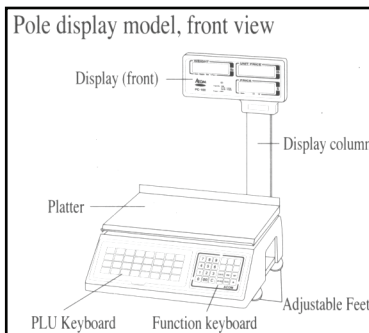

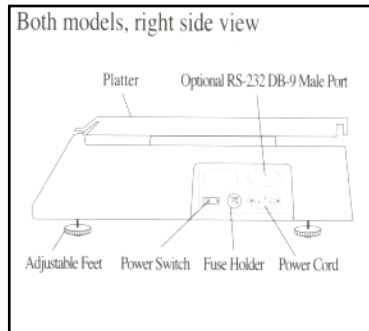
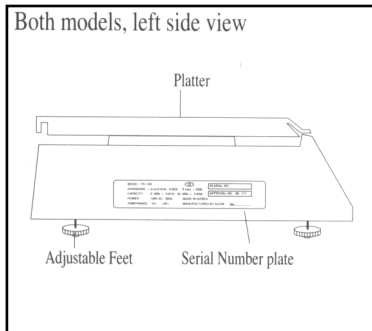
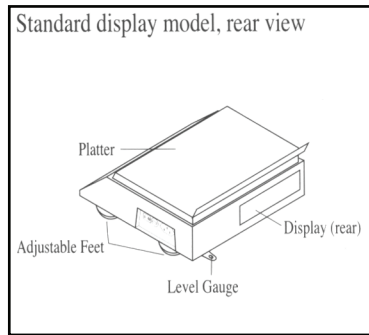
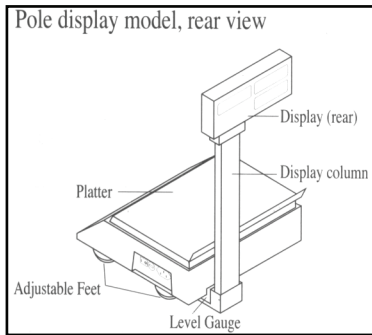

Function Keys

00 ~ 9	Numeric keys, used to enter pricing data, tare, programming, etc.
C	Clear key, used to release error conditions and to clear erroneous entries.
ZERO	Zero key, used to manually set the zero point.
TARE	Tare key, used to enter tares and clear tares.
SAVE	Save key, used to disable the price / tare auto-clear function.

MW	Memory Write, used to program PLUs.
MR	Memory Read, used to call-up PLUs.
1/2	1/2 key, used to price items by the half pound. (This key is not allowed in some states.)
1/4	1/4 key, used to price items by the quarter pound. (This key is not allowed in some states.)
*	* key, reserved for future use.
	Direct PLU keys, these are the 6 light blue keys located on the upper right-side of all PC-100 scales. Direct PLU keys can also be found on the left-side keypad of the PC-100 Pole Display model.

Display

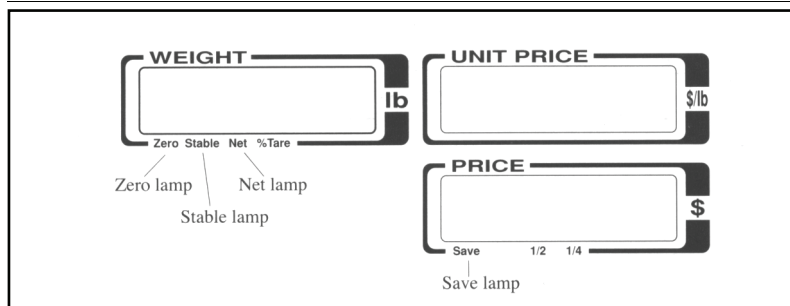

Zero lamp indicates that the scale is a gross zero.

Stable lamp indicates that the weight on the scale is stable.

Net lamp indicates that there is a tare set.

Save lamp indicates that the auto-clear feature is disabled.

Unpacking & Assembly

Your PC-100 scale should come with the following:

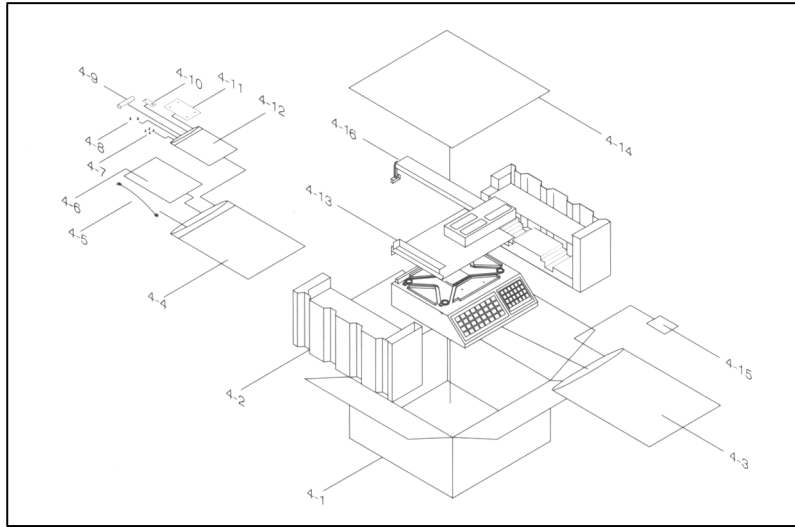

NO	Parts Name	Units	QTY
4-1	IN CARTON BOX	EA	1
4-2	STYROFOAM	EA	2
4-3	BODY POLY BAG	EA	1
4-4	MANUAL POLY BAG	EA	1
4-5	AC CORD	EA	1
4-6	MANUAL	EA	1
4-7	PAN SCREWS, pole model only	EA	4
4-8	CAL SEALING BOLTS	EA	2
4-9	FUZE	EA	1
4-10	CAL PLATE AND SEAL	EA	1
4-11	BRACKET COVER, pole model only	EA	1
4-12	FUZE POLY BAG	EA	1
4-13	STYROFOAM PAD	EA	2
4-14	BOX PAD	EA	1
4-15	SILICA DESICANT	EA	2
4-16	POLE DISPLAY, pole model only	EA	1

Once you have unboxed your PC-100 you must determine whether you have a Pole or Standard display model. If you have a Standard display model, simply connect the power cord to the scale and then to a 110 VAC 60 Hz outlet. If you have Pole display model follow the instructions below on how to assemble it.

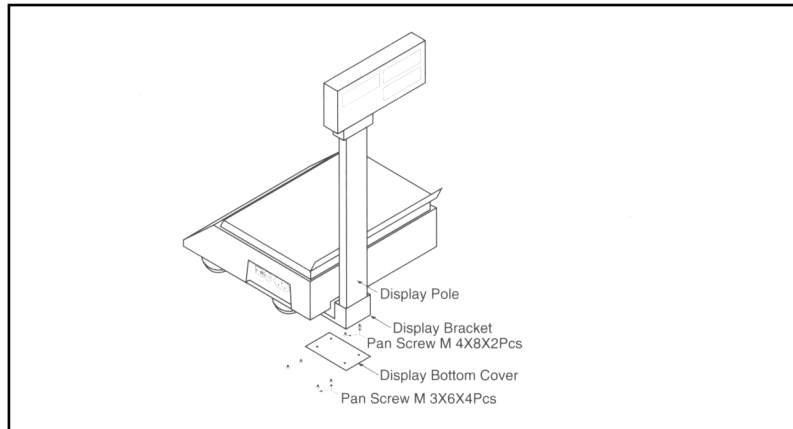

Safety Precautions

- Place the scale on a flat and rigid surface
- Place the scale far from strong RF interference
- Level the scale using its adjustable feet
- Do not subject the platter to sudden impacts
- Do not spill the water or any other liquid on the scale
- Do not use any solvents to clean the scale
- Do not remove the safety ground on the power cord

Operating the Scale

Make sure the platter is sitting properly on top of the platform and that there is nothing on top of the platter. Also, make sure that the scale is plugged into the proper outlet. Place the power switch into the ON position. The scale displays will run through a self test, count down to zero, and then beep. All of your displays should look as follows:



Simple Weighing:

1. Enter a unit price using the numeric keys and press the 1/2, 1/4, or 100g keys if necessary
2. Place an item on the platter
3. Remove the item from the platter

Steps 1 & 2 can be interchanged. After step 2 you will notice that the Total Price display will show the calculated Total Price. For example:



After step 3 you will notice that the displays will return to their initial state of 0.00.

Simple Weighing Using Known Tares:

1. Enter a tare weight using the numeric keys
2. Press TARE
3. Enter a unit price using the numeric keys and press the 1/2, 1/4, or 100g keys if necessary
4. Place an item on the platter
5. Remove the item from the platter

Steps 2 and 4 can be interchanged. Once you press the TARE key you will notice that the NET light will come on indicating to you that the weight shown is a net weight. For example:



After you place an item on the scale and enter a price the displays may look like this:



After step 5 you will notice that the displays will return to there initial state of 0.00.

Simple Weighing Using Known Tares:

1. Enter a tare weight using the numeric keys
2. Press TARE
3. Enter a unit price using the numeric keys and press the 1/2, 1/4, or 100g keys if necessary
4. Place an item on the platter
5. Remove the item from the platter

Steps 3 and 4 can be interchanged. Once you press the TARE key you will notice that the NET light will come on indicating to you that the weight shown is a net weight. The procedures for known and unknown tares is very similar

Disabling the Auto-Clear Feature:

If you press the SAVE key before any operations, the SAVE light will come on. This will prevent the Weight and Unit Price displays from auto-clearing which is very useful for pre-packing.

Weighing Using Direct PLUs:

1. Press the Direct PLU key on the keyboard and change the price if desired.
2. Place an item on the platter
3. Remove the item from the platter

Steps 1 and 2 can be interchanged. You can learn how to program Direct PLUs in the next section.

Weighing Using Indirect PLUs:

1. Type the PLU number and press the MR key and then change the price if desired.
2. Place an item on the platter
3. Remove the item from the platter

Steps 1 and 2 can be interchanged. You can learn how to program Indirect PLUs in the next section.

Program Mode

Pressing the MW key enters program mode. If you ever get stuck in Program mode you can press the * key which will allow you to ESCAPE back to normal mode.

Programming PLUs:

1. Press the C key and then press the MW key. The displays will show:



2. You can now enter the Unit Price for the PLU that you are programming and then press the MW key.

3. You can now enter a Tare weight for this PLU. The displays will now show the following:

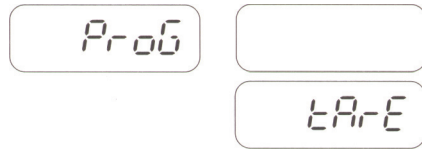

4. Once you have entered the Tare, press the MW key. Step 5 is Percent Tare programming. This feature can be disabled so if you do not see the following displays then go to step 6. **(Only an Easy Weigh™ Authorized Dealer can change this option.)**

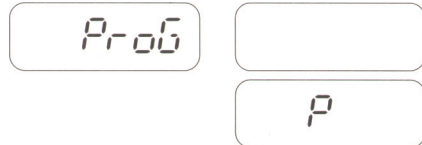

5. At this point you can enter a Percent Tare value. Remember, if your scale does not show this please go on to step 6. Once you have entered a %Tare, press the MW key. The displays will next show:

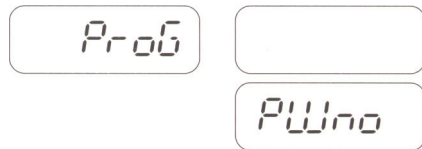

6. At this point you may type the PLU number that you wish to assign the above data to and then press the MW key, or you can press one of the Direct PLU keys to assign the data directly to that key. **Note that if you wish to program the speed keys located on the numeric keypad, you must refer to them as PLU number 1 thru 6. They cannot be programmed by pressing the actual key.** You are now done! You can repeat this procedure for other PLUs.

Remember, if you get stuck you can always press the * key to escape back to regular mode.

Check Stand Operation

If you have purchased your PC-100 scale with the RS-232 kit you will be able to interface your scale to a PC or virtually any ECR (Electronic Cash Register.) If you do not have this feature or aren't sure, please contact your local Easy Weigh™ Authorized Dealer to assist you. The following page will explain the RS-232 setup.

Type Setting:

The PC-100 communicates using the following protocol: **9600 Baud, Even Parity, 7 Data Bits, and 1 Stop Bit**. This is fixed and cannot be changed. However, there are different request codes and response data that can be selected. The following explains how set the different Type Settings.

1. Turn the scale OFF
2. Press and hold down the * key while you turn the scale ON
3. Release the * key once you hear the scale beep
4. You will see a value in the Unit Price display. You may change this value according to the chart below.
5. Once you are done setting the value, press the * key

Basic Description	Type Setting
Disable RS-232 Port	00
NCI General Interface (Most P.O.S. Systems)	01
NCI ECR Interface (Most Cash Registers)	02
Toledo 8213 (Many Cash Registers)	03
Stream Mode	10
Hand Shake Mode	20

See page 12 for Cash Register and personal computer model cross reference chart. You will find that the PC-100 scale will interface to the most popular makes and models. There are some cable diagrams on page 11 that you may find useful.

Brand and product names are trademarks and/or registered trademarks of their respective companies.

Options & Accessories

The following options are available through your Easy Weigh™ Authorized dealer:

Description	Part Number
Fish Pan Platter	260-00001-020001
RS-232 Kit	070-10001-020000
Spill-Proof Overlay (Wet cover)	101-00001-020000
AC Power cord	690-00001-02002M
Adjusting feet (set of 4)	4B0-00001-020000

For any type of service or troubleshooting, please contact your nearest Easy Weigh™ Authorized dealer. DO NOT attempt to service, repair, or disassemble this or any scale as this is legally permissible to only licensed professionals.

Troubleshooting & Error Messages

Error	Description	Solution
Zero	Initial zero range error	Empty the platter, turn OFF and ON. If this occurs again then call service
AdC	Analog circuit failure	Call service
EEP	Memory failure	Call service
PArA	Parameter failure	Call service

Cable Diagrams

PC-100 to IBM PC & Compatibles			
	PC-100 DB-9 Pin Male	IBM PC DB-9 Pin Female	
TX	3	2	RX
RX	2	3	TX
SG	5	5	SG
		4	DTR
		6	DSR
		7	RTS
		8	CTS

PC-100 to IBM PC & Compatibles			
	PC-100 DB-9 Pin Male	IBM PC DB-25 Pin Female	
TX	3	3	RX
RX	2	2	TX
SG	5	7	SG
		20	DTR
		6	DSR
		4	RTS
		5	CTS

A complete list of cable diagrams is located at:
<http://www.easyweighscales.com/docs/PC-100 Cable Diagrams P.pdf/>

A complete list of cable diagrams is also located in the PC-100 Service Manual.

Interface Cross Reference Chart

Make	Type Setting	Models
Casio	01	SA-3000
CRS	02	CRS-3000
DataSym	02	DT-2000 and all newer models that follow
Esper	02	7810, 9700
IBM PC	01	IBM PCs and compatibles with 25 pin serial ports
IBM PC	01	IBM PCs and compatibles with 9 pin serial ports
NCR	02	2170, 7452, 7453, 7445, and all newer models that follow
Omron	02	RS-4841, Vantage 7000, and all newer models that follow
Panasonic	02	Panasonic ECRs with serial interfaces
Samsung	02	ER-550, 650, 6500, 6540
Samsung	02	ER-5100, 5140
Sanyo	03	ECR-425, and all newer models that follow
Sharp	03	ER-A880, 750, 650, 570, 470, and all newer models that follow
Swintec	02	2250, with 25 pin serial ports
Swintec	02	2250, with 9 pin serial ports
Uniwell	02	UX-7500, 6000, 4001, 70, 60, and all newer models that follow

A complete Interface Cross reference chart is located at:
<http://www.easyweighscales.com/docs/PC-100 Cable Diagrams P.pdf/>

A complete Interface Cross reference chart is also located in the Service Manual for the PC-100.

For more information go to:
<http://www.easyweighscales.com/techs.htm#PC-100 Techs>

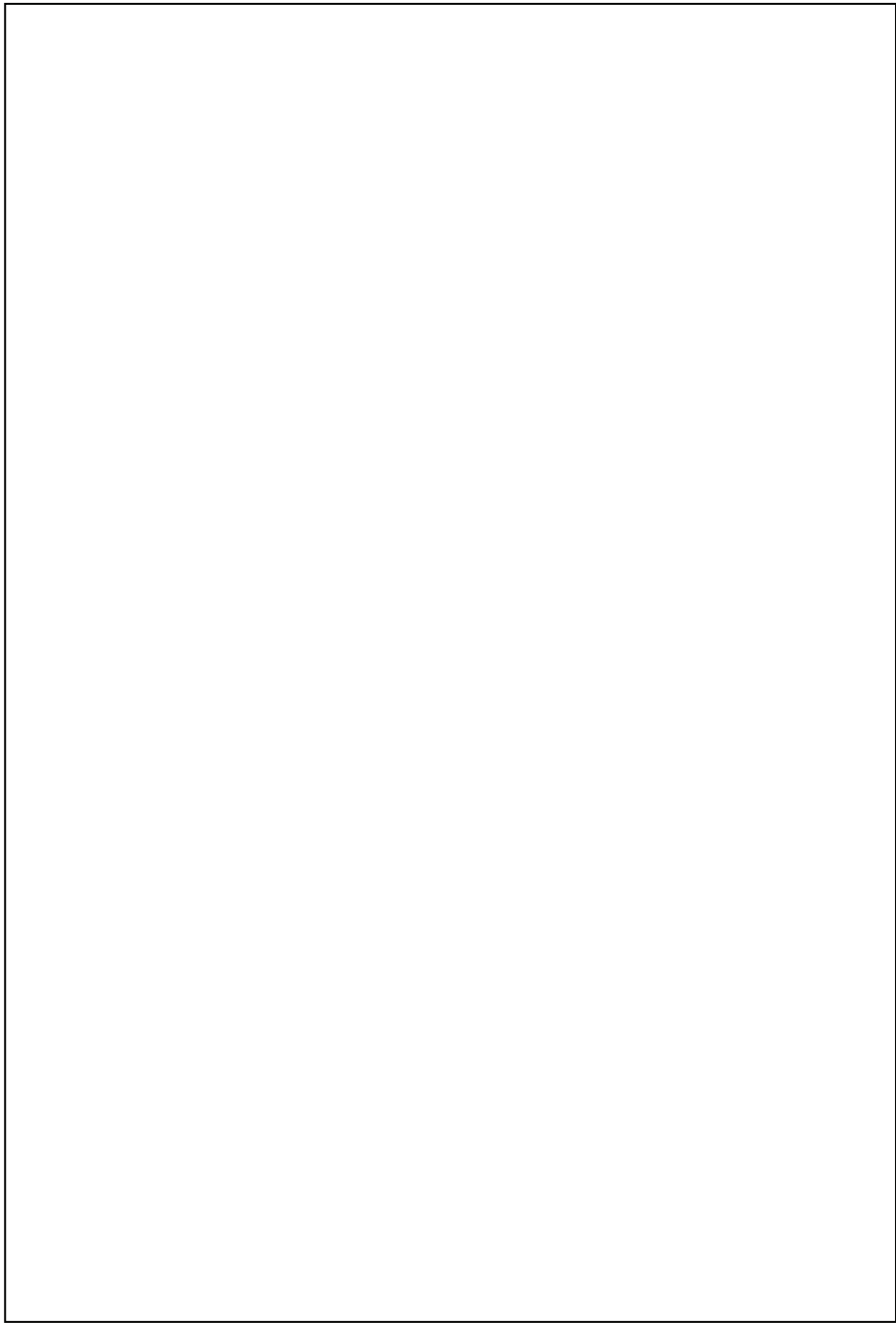



Easy Weigh

www.atronsystems.com

Copyright 2005, All rights reserved.

800-20101-020000